

DUCKPIN BOWLING



POWERED BY **FUNK**

WWW.DUCKPINBOWL.COM



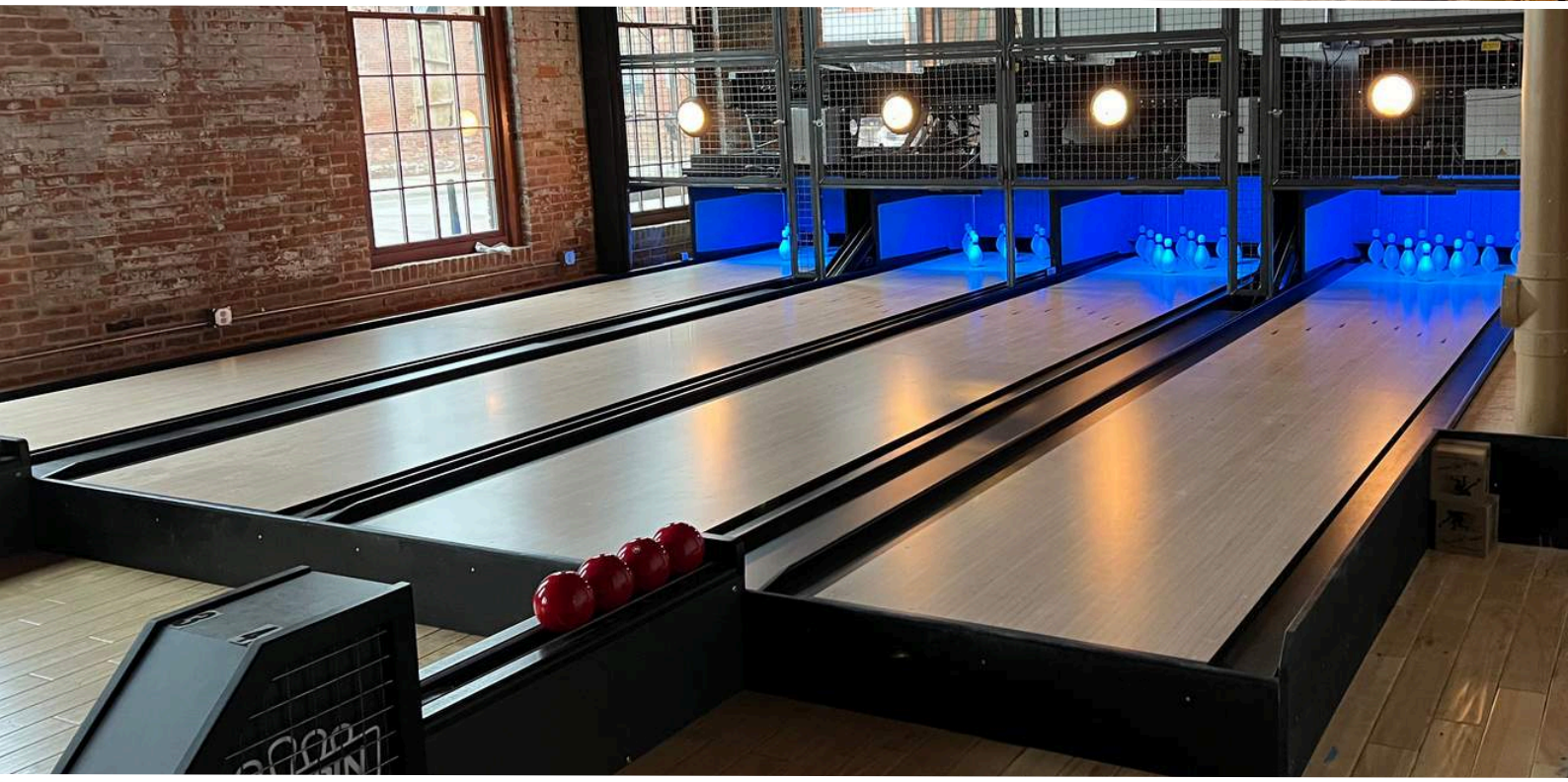

ACCESSIBLE. SOCIAL. BOWLING.



Offer a new experience to your guests. Duckpin Bowling is available at any time, easy to play, a customer magnet and sales turbo.

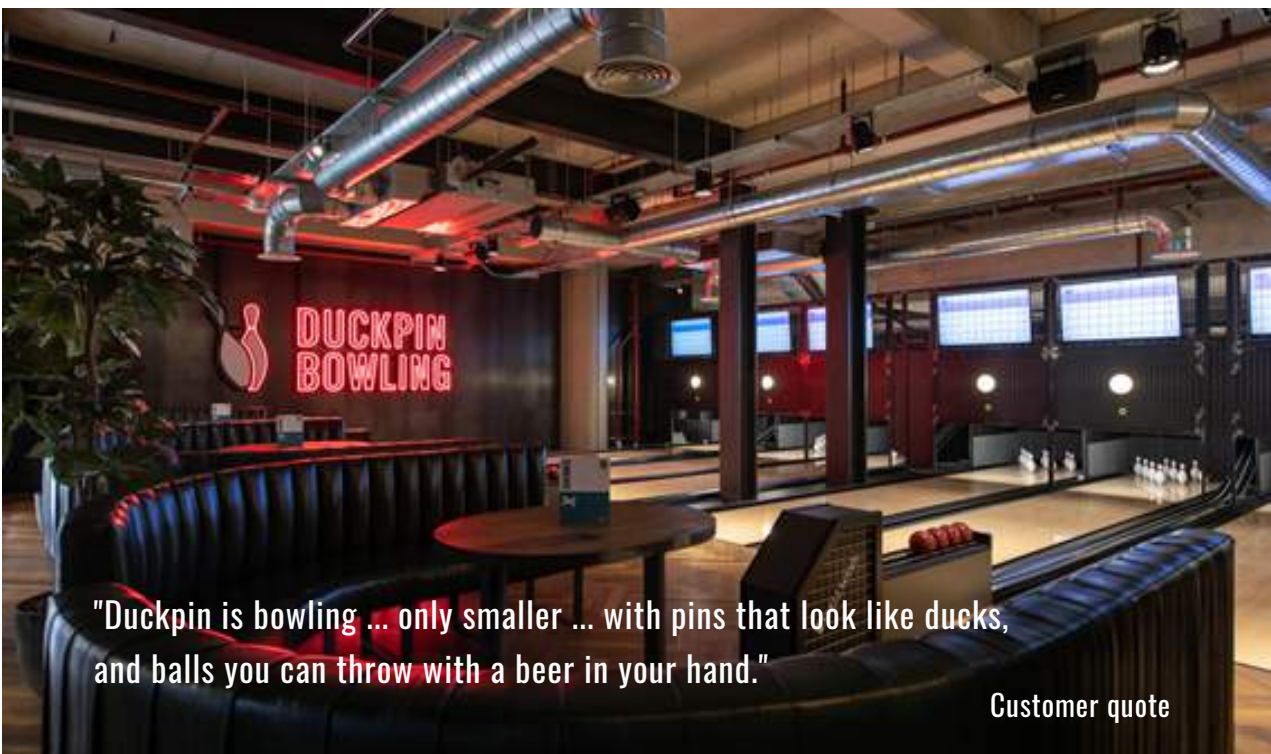

"Duckpin is bowling ... only smaller ... with pins that look like ducks, and balls you can throw with a beer in your hand."

Customer quote



UNIQUE

Duckpin gives you a significant competitive advantage. Delight your guests with an unforgettable entertainment experience. Duckpin bowling is cool.

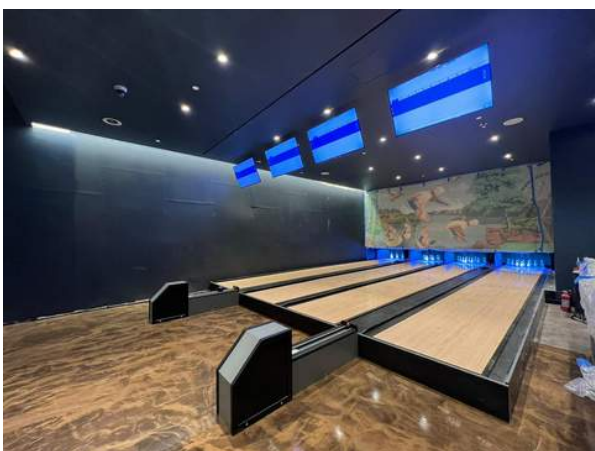

ADAPTABLE

As individual as you are! Your location is unique - and your new Duckpin system fits seamlessly into your interior design.

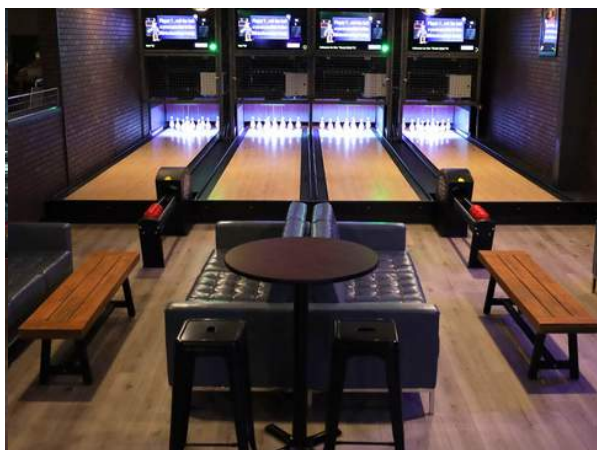

QUICK AND INDIVIDUAL

Modular construction, manufactured in our own production plant, installed by our own staff. This way, the Duckpin systems find a place in every location. After a short assembly time, the first balls are already rolling.



REVENUE SOURCE

Your guests will love Duckpin: No other gaming device combines entertainment, conviviality and gastronomic consumption better. The operators of our Duckpin facilities not only enjoy income from the use of the equipment, but also noticeably higher catering turnover.

INDIVIDUAL JUST LIKE YOUR LOCATION



100% CUSTOMIZABLE

The Duckpin system should support your design and furnishings, which is why it is customised for you. As a manufacturer in Germany, FUNK is able to realise your wishes directly during production. Be it design, size or additional equipment - you will find the right solution here.

The length of the Duckpin track can be flexibly customised. Standard length 990 cm (incl. run-up area).

Number of Lanes	Width Centimeters
1	169
2	312
4	615
6	933
8	1243

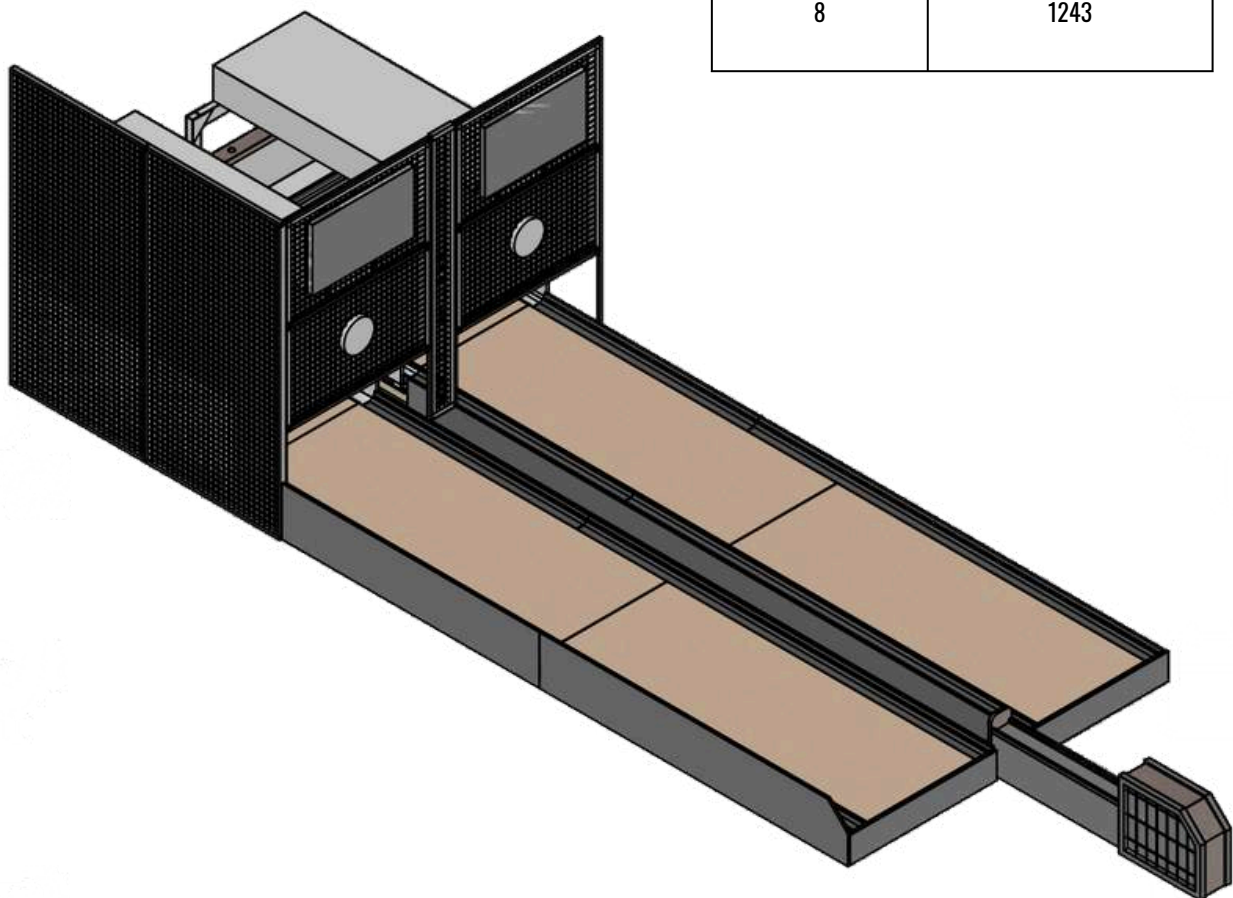



The origins of duckpin date back to the 1890s. Today, a large number of passionate players can be found in all countries of the world. More and more people are turning from casual users into enthusiastic devotees. There are many reasons for this: Duckpin is simple, fun and the ideal game for social get-togethers with friends. For the operators ,Duckpin ensures a permanently high customer frequency and increased turnover.

Company headquarters, breweries, hotels, bars, restaurants ... Duckpin connects people in places where you wouldn't expect to find bowling. Duckpin fits into any location: shorter lanes, smaller balls, special pins, etc.

FUNK Duckpin stands for quality: The Duckpin systems use components from FUNK BOWLING that have been tried and tested over many years. Know-How. Reliability. Made in Germany. Since 1964.



THE FUNK QUALITY PROMISE

- A company tradition that goes back to 1885.
- A unique expertise in the development and manufacture of rope pinsetters since 1964.
- A medium-sized family business that is now being managed by the third generation and is ideally equipped for the opportunities and challenges of the coming decades.

GERMAN QUALITY

The name FUNK BOWLING stands for the highest quality standards and durability of its products. The vertical range of manufacture at the two production sites in Laatzen and Maselheim is unique. Customers receive their complete bowling equipment from one source.

100% FUNK. 100% quality.

EXPERIENCE AND EXPERTISE

Thanks to decades of practice, FUNK BOWLING has extensive expertise in the field of bowling and skittles. The experts in the company are very familiar with the requirements and needs of bowling centres and develop tailor-made solutions for their long-term success. 100% flexibility. 100% customer focus.

USBC CERTIFICATION

The requirements and decisions of the USBC are influential and trend-setting for the sport of bowling in all countries of the world. The USBC certification of the FUNK Pinsetter machine therefore ensures that the technical equipment of the bowling centres meets the high standards of the largest national bowling federation: They are fit for upcoming developments and send a clear signal regarding their own quality standards.

FAMILY BUSINESS

As an owner-managed family business, FUNK BOWLING relies on continuity and a long-term approach - with FUNK bowling products as well as with regard to its own corporate values. Three generations unite tradition, the present and future development potential within one organization.



The FUNK Family: Alexander Funk, Karl-Heinz Funk, Karl Funk (f.l.t.r.)



The headquarters in Maselheim-Äpfingen



FUNK North branch in Laatzen (formerly Spellmann)

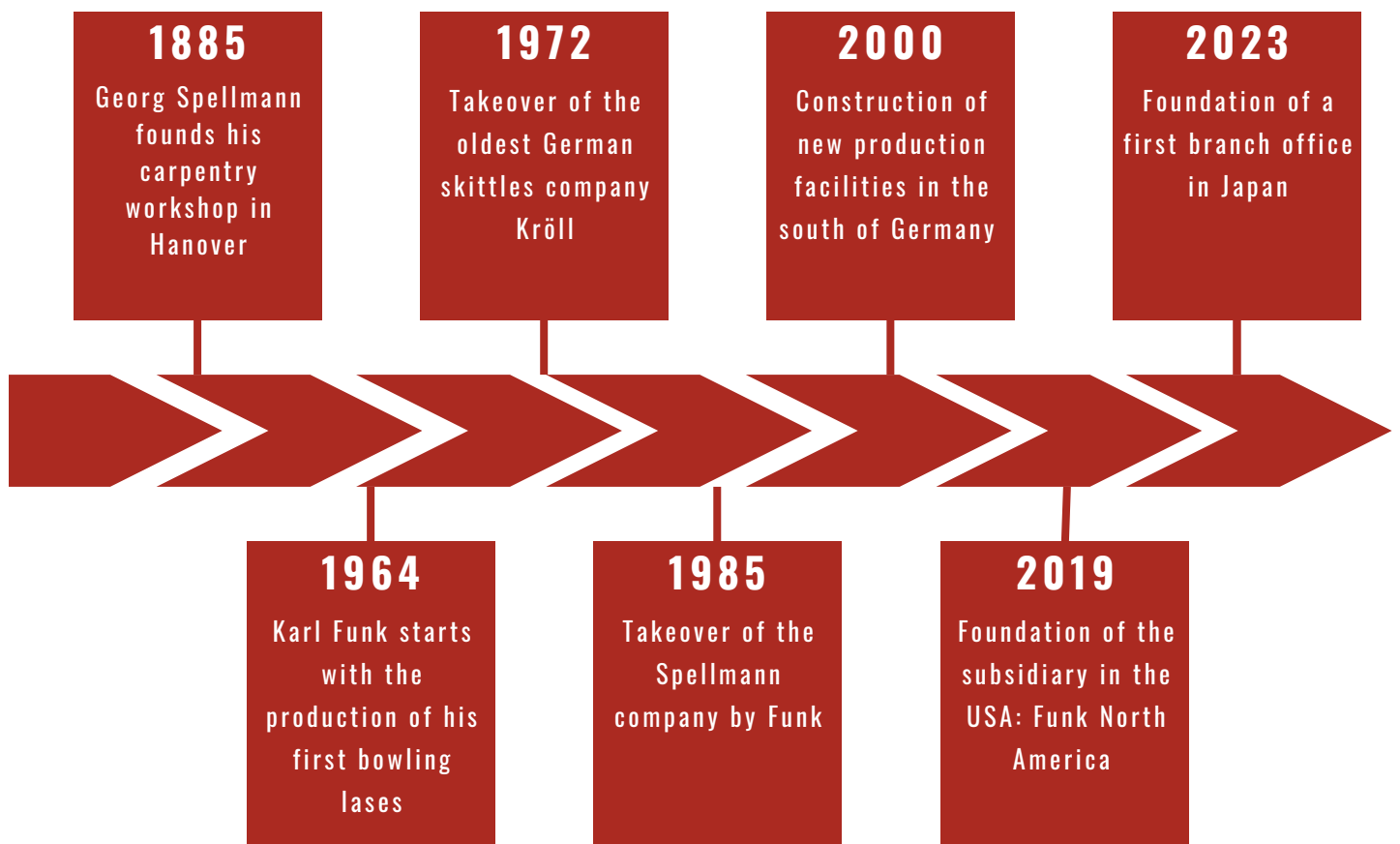

Karl Funk GmbH & Co. KG
An der Schnellstraße 6
88437 Maselheim-Äpfingen
Germany

phone +49 (0) 7356 / 9370-0
mail info@funk-bowling.de

